

creation 2015  
Company Transe Express

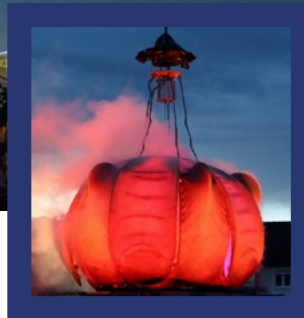

# Mū

*Cinématique des Fluides*



## *One city, one night*

In the heart of the city, emerging from a faint glow, one guesses a silhouette perched on two containers.

The crowd who gathers around will suddenly discover a tiny gardener on the hook of the crane. A winged woman equipped with a watering can will water here and there the flowers on balconies, the trees and everything she finds in her way: the city is her giant garden ... Making a way through the crowd, a horde of surrealist objects conducted by a shaggy and weathered by time figure, arrives just in front of the drizzle from the sky.

It leads to a furious outbreak of the giant shell, foreshadowing a ballet between earth and heaven, promising an adventure and a life-saving journey which will take them over the elements to the track to the stars.

## *Upside down*

**Mū – Kinematic of fluids is a fantastic and poetic trip through the material.**

The mystics call it Genesis. Scientists name it the Big Bang. We'll just play poets and evoke sensitively the origin of the material. We will play the alchemists and walk you through the table of elements.

A trip 'From the Earth to the Moon' follows the footsteps of the giant Jules Verne. You will go through all states, transfigured by the music of stamen instruments from a land anemone and sounds of a star in a perpetual motion.

Salamander gargoyles straight out of their mineral sleep will serve you as a catalyst to walk through fire without burning your wings; you will fly on the croup of an air stream and prepare for the big dive into the heart of the abyss.

Like in a Jérôme Bosch painting, fish leave the bowl and the machinery becomes organic- it's by the siren song we will be all immersed in the same euphoria bath of sea floor.

## between earth and sky

It's a large scale aerial performance, monumental and bright, where music, images, physically and technical prowess will make your heart beat faster. Designed as an immersion in the material, the show involves a monumental structure, which opens like a giant music box. Handled by a telescopic crane, a sculpture in the air dialogues with an articulated structure perched on two containers. Bright parades created by twenty local volunteers will immerse the crowd in a collective narcosis. The Show was created by the new and former artistic team of the company.

# generic

--

## creation

### COLLECTIVE WRITING :

Rémi Allaigre, Mickaël Belle, David Frier, Matthieu Neumann, Ivan Tziboulsky, Gilles Rhode

**SCENOGRAPHY :** Rémi Allaigre, Gilles Rhode

**PERFORMERS COACH :** Alberto Nason

**CHOREOGRAPHY :** Brigitte Burdin, Amélie Kourim

**ENGINEERING :** Pierre Garabiol, Mickaël Belle

**COMPOSITION :** Philippe Gilbert, Léopold Plastaga, Rémi Allaigre

**LIGHT DESIGN :** TILT- François Fouilhé, Jean-Baptiste Laude

**COSTUME AND ACCESSORIES :** David Frier, Céline Carraud, Clothilde Laude, Gilles Rhode

### MUSICIANS :

contrebasse : Amanda Gardone, Marc de Sousa

saxophone : Eric Houdart, Lionel Garcin

trompette : Vincent Stephan, Laurent Arn

xylophone : Raphael Carrara, Ivan Tziboulsky

batterie : Audric Fumet, Louis Gaumeton

**ACROBATS :** Tarzana Fourès, Thibault Lapeyre, Lutz Christian, Guillaume Amaro, Marika Mazzanti

**SINGERS :** Karole Seyve, Maryvette Lair, Franck Saurel, Harold Savary

**TRAINERS :** Rémi Allaigre, David Frier, Mathieu Neumann, Olivier Balagna

**TECHNICIANS :** Frank Gaffiot, Laurent Dolques,

Arnaud Barbiéri, Agop Djevahirdjian,

Guillaume Gratseol, Patrick Figgie, Loïc Marijon

## supports

- > DRAC Rhône-Alpes : agreement
- > Région Rhône-Alpes : agreement
- > Conseil Général de La Drôme : creation support
- > Ministère de la Culture – DGCA : support to artist residency
- > Atelier 231 – National center of street arts – Sotteville-Lès-Rouen : Creation support and welcome in residency
- > Le Parapluie – National center of street arts – Aurillac : Creation support and welcome in residency
- > L'Abattoir – National center of street arts Chalonsur-Saône : Production support
- > Bonlieu – SN Annecy : Creation support
- > La Gare à Coullisses : welcome in permanent residency



## some dates

### 2018

27 Juin / Fusion Festival / Lärz, Germany

04 août / Temudas Festival / Las Palmas, Canary Islands

17 août / Kunstfest / Weimar, Germany

### 2017

10 et 11 Février / Winter Vonken / Brugge, Belgium

10 Juin / Stiftung Schloss / Neuhardenberg, Germany

30 juin / Festival a Corte / Turin, Italy

14 juillet / Ville d'Armentières et Métropole européenne de Lille - 59

30 juillet / Festival de Almagro, Spain

16 septembre / Festin de Pierres / St Jean de Védas - 34

### 2016

02 juillet / SO Festival / Skegness, UK

07 au 09 juillet / Deventer op Stelten / Deventer, Netherlands

06 août / La Strada Festival / Graz, Austria

11 au 15 août / Sziget Festival / Budapest, Hungary

20 août / Spancirfest / Varazdin, Croatia

26 août / Fête de la Mirabelle / Metz - 57

08 octobre / Garges Les Gonesses - 95

16 octobre / Arts Festival / Belfast, Ireland

18 décembre / Ville de La Roche sur Yon - 85

### 2015

16 mai / Sol y Fiesta / Port Leucate -11

10 juillet / Nuits Romanes / Fontaine Le Comte - 86

18 juillet / Les Noctibules / Annecy - 74

22 et 23 juillet / Chalon dans la Rue / Chalon sur Saône - 71

12 septembre / Cergy Soit ! / Cergy - 95

18 septembre / Festival international de marionnettes / Charleville Mézières - 08



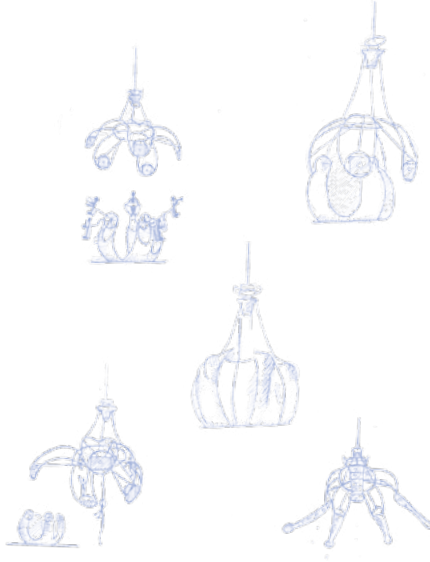

# technical rider

--



**TYPE** Giant urban scenography with music, theater, visual arts and prowess.

**SCALE** Aerial fixed show with parades from the central. Nocturnal show for thousands of people

**DURATION** 50 minutes

**SITE** Need a place large enough to contain the structure and the imagined public (space minimum 2 000m<sup>2</sup>) / interesting architectural sites.

**SITE VISIT** A previous site visit will be organized in the presence of our company manager, the organizer, the technical director of the venue and the crane operator.

**HOUSING** Arrival of the company D-2 in the evening.

**TEAM** Artists (12 people): 5 acrobats, 5 musicians, 2 trainers for the volunteers.  
Technicians (6 people): 1 general director, 1 sound technician, 1 light manager, 2 structure managers, 1 production manager.

**VOLOUNTEER** 20 volunteers are necessary for the parades.

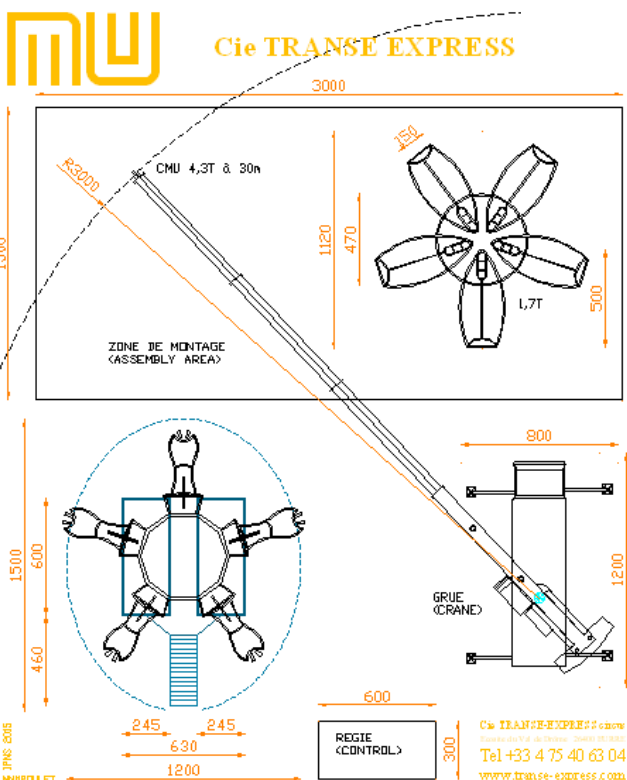

## MATERIALS PROVIDED BY THE ORGANIZER

**LIFTING** Telescopic crane 100 to 120 tons, with imperatively an inclined flying jib at 15°/30°.

**SOUND & LIGHTING** Detailed Rider upon request

**SAFETY** Traffic and parking prohibited at the show location from the beginning of the set-up to the end of the break-down.

# Transe Express

inventors of imagination

The company Transe Express performs in outdoor spaces to meet the audience. The combination of theatre and music is used as a melting pot of spectacular sciences: visual arts, dance, fire, prowess's...

Shock creations which at times invest a stage, non-conventional spaces but principally the streets; intriguing the public in their everyday lives; unique adventures to transform a city, to create a memorable moment in time.

Brigitte Burdin, choreographer, and Gilles Rhode, visual artist, founded Transe Express in 1982. They created over the years a style, an esthetic "Aerial Art"; they also included many others in the adventure and formed artists and designers, to whom they transmitted the artistic direction in 2015.

This team of creators is co-led by Rémi Allaigre, Hélène Marseille and Eléonore Guillemaud, with the willingness and the pleasure to continue and grow The "Transe Express Spirit".

Based in its permanent residence "la Gare à Couliesses", base of street arts open to local and passing companies, Transe Express is employing today 160 artists and technicians.

It is in this "artistic Workshop factory" in Eure in the Valley of Drôme that the team Transe Express invents and carries out its ephemeral creations or repertory shows with a predilection for Monumental and Aerial Art, but without forgetting the pleasure of the proximity with the public.

It was illustrated in particular for the opening of the Albertville Olympic Games in 1992, in Paris - Beaubourg with «Les 2000 Coups de Minuit», with «Roue-Ages» in Paris for the year 2000, for the opening of the Sydney Festival in 2002 and 2005, for the opening of the biggest South American festival, the Santiago a Mil festival in Chile in 2011, as part of Marseille Provence 2013, for the Chinese New Year in Hong-Kong in 2015, at the Sziget Festival in Budapest in 2016 and in Montreal for the 375th birthday of the city in 2017.

The shows of Transe Express seduced the public of 74 countries around the world, on the 5 continents.

## CREATIONS

- 1984 Wouar Chou Bou Lou, comédie de gestes
- 1985 Cirque de Caractère, co-réalisation Archaos
- 1986 Les Tribulations de Rosemonde, spectacle jeune public
- 1987 Itinéraire Bis, cheminement spectaculaire
- 1988 Bar Barre, danse-théâtre
- 1989 Les Tambours, spectacle déambulatoire
- 1990 Mobile Homme, attraction aérienne
- 1991 Phénomène, théâtre fantastique jazz
- 1991 Avis de tempête, musique de rue et d'orage
- 1992 L'Homme catapulté, attraction foraine
- 1993 TNT, comédie de rythme et de geste
- 1994 Héphaïstos, rituel de rythme et de feu
- 1996 Maudits Sonnants, art céleste
- 1997 Ouh... les cornes, conte imagé
- 1999 Lâcher de Violons, l'émotion verticale
- 1999 Roue-Ages, Champs Elysées
- 2000 Cocagne, boîte à musique monumentale
- 2000 Les 2000 Coups de Minuit, Beaubourg
- 2004 Les Rois Faignants, fresque naïve et urbaine
- 2006 M.O.B., Mobile Oblique et Bancal
- 2008 Cabaret chromatic, spectacle fauve
- 2011 Tambours de la Muerte, célébration iconoclaste, pyromaniaque et percutante
- 2012 Diva d'eau, Opérette Aqua fantastique
- 2013 Colin Tampon - Escorte percutante au service du Quidam
- 2013 Poupées Géantes - Opéra urbain
- 2015 Mû - Cinématique des Fluides
- 2016 Vivace Monument - Création in situ
- 2017 The Moniks - Band of Brothers
- 2018 Cristal Palace - Bal au clair de lustre

COMPAGNIE  
**TRANSE EXPRESS**  
cirque

INVENTEURS  
D'IMAGINAIRE  
GARE À COULISSES  
ECOSITE - 26400 EURRE - FR  
TEL + 33 (0)4 75 40 63 04  
www.transe-express.com

